

15 METERS MAXIMUM HOSE CAPACITY

508 810

FLUIDS HANDLED

- Water.
- Diesel.

MARKETS / APPLICATIONS

- Fleets.
- Lube trucks.
- Mining and construction.
- Railroad and mass transit.
- General manufacturing.

MOUNTING

- Floor.
- Tank.

Full metal, Intensive Duty, hose reel with hose capacity up to 15 m x 1-1/2" hose.



04
HOSE REELS

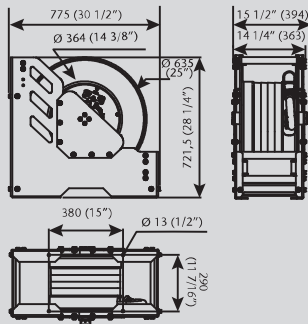

Dimensions mm (inches)

- Very tough construction large delivery reels, able to stand regular use and abuse in Intensive Duty applications.
- Fatigue resistant steel spring for years of durable performance and even load when pulling and recoiling the hose.
- Full port shaft and swivel for no restrictions.
- Spool mounted on two permanent lubricated and sealed ball bearings to reduce torque load on spring for smooth retraction and longer life.
- Large effective radial latching area for easier operation.
- Hose guide arm can be placed in two different positions to accommodate any method of mounting.
- Narrow footprint allows accommodating more reels on the same surface.

PART No.	BARE REEL	HOSE IN \varnothing	HOSE LENGTH	CONNECTING HOSE INLET	DELIVERY HOSE OUTLET	PRESSURE RATING	WEIGHT (With hose)
WATER / DIESEL							
508 810	508 890	1-1/2"	15 m	1-1/2" BSP (F)	1-1/2" BSP (F)	20 bar	87 kg

Wellington Head Office: 90 Sydney St, PO Box 38 720
 Petone, Wellington, Tel: 64 4 568 4933, Fax: 64 4 568 4789
 Email: sales@liquip.co.nz Website: www.liquip.co.nz