

506 202

15, 20, 25 AND 30 METERS MAXIMUM HOSE CAPACITY

FLUIDS HANDLED

- Air.
- Water.
- Antifreeze solutions.
- Synthetic and mineral oils.
- Waste Oil Evacuation.
- Diesel.

MARKETS / APPLICATIONS

- Fleets.
- Lube trucks.
- Mining and construction.
- Railroad and mass transit vehicles.
- General manufacturing.

MOUNTING

- Floor.
- Tank.

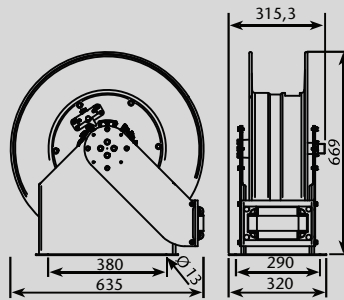

Dimensions (mm)

Full metal, Intensive Duty, double pedestal hose reels, with hose capacity up to 15 m x 1", 20 m or 25 m x 3/4" hose and 30 m x 1/2" hose.



- Very tough construction large capacity reels, able to stand regular use and abuse in Intensive Duty applications.
- Fatigue resistant steel spring for years of durable performance and even load when pulling and recoiling the hose.
- Full port shaft and swivel for no restrictions.
- Spool mounted on two permanent lubricated and sealed ball bearings to reduce torque load on spring for smooth retraction and longer life.
- Large effective radial latching area for easier operation.
- Hose guide arm can be placed in different positions to accommodate any method of mounting.
- Narrow footprint allows accommodating more reels on the same surface.
- Hose reels with hose include 0,8 m inlet hose.

PART No.	BARE REEL	HOSE INSIDE DIAMETER	HOSE LENGTH	CONNECTING HOSE INLET	DELIVERY HOSE OUTLET	PRESSURE RATING	WEIGHT (With hose)
AIR / WATER / ANTIFREEZE SOLUTIONS / DIESEL							
508 125	508 925	1"	15 m	1" BSP (F)	1" BSP (F)	25 bar	50 kg
LUBRICANTS / WASTE OIL EVACUATION							
508 225	508 925	1"	15 m	1" BSP (F)	1" BSP (F)	90 bar	56 kg
508 234	508 924	3/4"	20 m	1" BSP (F)	3/4" BSP (F)	100 bar	55 kg
508 244	508 944	3/4"	25 m	1" BSP (F)	3/4" BSP (F)	100 bar	57 kg
508 252	508 942	1/2"	30 m	1" BSP (F)	1/2" BSP (F)	160 bar	55 kg