

SERIES 670 / 6670

End-of-Line Deflagration Flame Arrester

Suitable for use with NEC Group D (IEC Explosion Group IIA) Vapors



PROTECTOSEAL

- Sizes 1" through 4"
- Listed by Underwriters Laboratories in 1" and 2" sizes
- Suitable for use with vapors equivalent to NEC 500 Group D, IEC Group IIA
- Vertically mounted, parallel plate-type flame arrester
- Protects against fire
- Minimizes pressure drop under normal operating conditions
- Easy inspection and maintenance
- Factory inspected prior to shipment
- Available in Aluminum and Stainless Steel



SERIES
670
6670

OBJECTIVE

The Series 670/6670 Flame Arresters are designed to provide flame stopping protection for a tank's vapor space when mounted to the end of a tank nozzle leading directly to atmosphere. The arresters prevent a flame front generated by an unconfined deflagration occurring outside the tank from propagating into the vapor space.

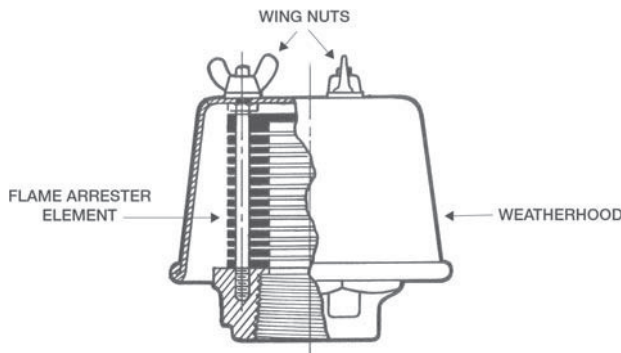

VAPOR GROUPS

The arresters are intended for use with vapors equivalent to Group D of the National Electric Code (NEC 500), IEC Group IIA. For arresters suitable for use with NEC Group C, IEC Group IIB3, please refer to Protectoseal Series 670E.

TECHNIQUE

The arrester is mounted on the end of a vent pipe from the tank. Vapors are allowed to escape into the atmosphere and air can be drawn into the tank through the specially designed flame arrester grid assembly. If an ignition source outside the tank is encountered, the flame arrester provides protection for the tank contents.

SPECIAL FEATURES

Easy Inspection, Installation and Maintenance. Design and light weight of unit permit easy, convenient handling for inspection, installation and maintenance. The weatherhood is readily removable by loosening just a few extra large wing nuts.



Automatic Condensate Drainage. Vertically mounted, circular plate-type flame arrester is employed for self-drainage of condensate. This prevents accumulation of condensate subject to freezing and consequent clogging of the arrester under low temperature conditions.

Positive Flame Arresting. The Series 670/6670 employs a circular-plate, precisely-spaced, type flame arrester to protect tank contents by preventing the propagation of fire into the tank. Precision embossings on alternate plates provide correct air-spacing for flame arresting function. Plates are fabricated from 1/16" to 3/32" heavy gauge metal, depending on material of construction, to resist distortion and bending during cleaning.

Sizes Available. 1", 2", 3" and 4" have standard NPT female threaded connections. Adapter flanges are available in these sizes. Refer to dimension chart on reverse for flange connection details. Refer to Series 670E for 6" size.

Test Lab Listings. Listed by Underwriters Laboratories (UL) in 1" and 2" sizes. For arresters that meet ATEX Directive 94/9/EC Standards EN 12874 & ISO 16852, please refer to Series 670E.

PRO-FLOW III® Sizing and Selection Software. Use PRO-FLOW III® to calculate flame arrester flow requirements in accordance with API 2000, ISO 28300, NFPA 30 and OSHA 1910.106.

Quality Assurance. Each unit is inspected to meet Protectoseal's high standards prior to shipment.

CONSTRUCTION

A comprehensive range of materials is offered as shown in the chart below. Other materials and features can be furnished upon request.

Available Options.

- Material certifications for castings

Series	Body	Hood	Nipple Flange	Flame Arrester Grid Assembly
670	Aluminum	Aluminum	Aluminum	Aluminum
6670	Aluminum	Aluminum	Aluminum	Aluminum
F670	316 S.S.	316 S.S.	316 S.S.	316 S.S.
FF6670	316 S.S.	316 S.S.	316 S.S.	316 S.S.

NOTE: Aluminum flanged to mate with 125# ANSI FF flanges. 316 S.S. models mate with 150# ANSI RF flanges.

Suitable for use with
NEC Group D
chemical vapors,
generally equivalent
to Electrotechnical
Commission (IEC)
Group IIA

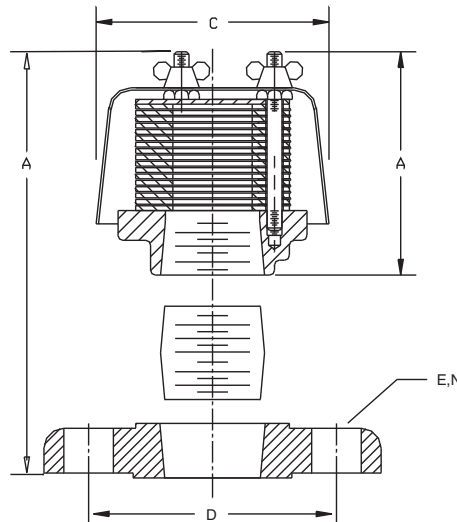

For arresters
suitable for use with
NEC Group C,
IEC Group IIB3,
please refer to
Protectoseal
Series 670E

DIMENSIONS

(NOTE: Dimensions shown are for reference only, contact Factory for certified drawings.)

Cat. No.*	Connection			Ht A	Dia C	B.C D	Dia. E	Holes N	Type Approval
	FNPT	ANSI**	DIN 16 PN						
671	1"	-	-	2.88" (73mm)	3.38" (86mm)	-	-	-	UL
671F	-	1"	-	4.4" (112mm)	3.38" (86mm)	3.13" (80mm)	.63" (16mm)	4	UL
See Series 670E	-	-	DN 25	-	-	-	-	-	Note 1
6672	2"	-	-	4.63" (117mm)	6.13" (156mm)	-	-	-	UL
6672F	-	2"	-	7" (178mm)	6.13" (156mm)	4.75" (120mm)	.75" (19mm)	4	UL
See Series 670E	-	-	DN 50	-	-	-	-	-	Note 1
673B	3"	-	-	8" (203mm)	7.5" (191mm)	-	-	-	-
673BF	-	3"	-	9.88" (251mm)	7.5" (191mm)	6" (152mm)	.75" (19mm)	4	-
See Series 670E	-	-	DN 80	-	-	-	-	-	Note 1
674	4"	-	-	7.38" (187mm)	8.5" (216mm)	-	-	-	-
674F	-	4"	-	9.38" (238mm)	8.5" (216mm)	7.5" (190mm)	.75" (19mm)	8	-
See Series 670E	-	-	DN 100	-	-	-	-	-	Note 1

* Cat. No. designates all Aluminum construction, please refer to chart on reverse for other materials.

** Aluminum flanged to mate with 125# ANSI FF flanges. 316 S.S. models mate with 150# ANSI RF flanges.

Note 1: Type Approved according to ATEX Directive 94/9/EC, Standards EN 12874 and ISO 16852 (Refer to Protectoseal Series 670E)

For larger sizes. . . Refer to Protectoseal Series No. 860 or Series No. 670E

ADDITIONAL PRODUCTS FROM PROTECTOSEAL

Series 670E (Group C, IIB3)



Type Approved according to ATEX Directive 94/9/EC, Standards EN 12874 and ISO 16852. Suitable for use with NEC Groups C or D (IEC Groups IIB3 or IIA).

Series 860 (Group D, IIA)



End-of-Line Deflagration Flame Arrester provides protection of the tank's vapor space if an ignition source is introduced outside of the tank. Suitable for NEC Group D (IEC Group IIA) vapors.

Series 18540



Pipe-Away Pressure Vacuum Relief Vent for applications that require hazardous vapors be processed into manifolded piping and not released into the atmosphere.

Series 830



Combination Pressure / Vacuum Relief Vent & Flame Arrester provides pressure and vacuum relief as well as protection from propagation of externally introduced flames. Suitable for NEC Group D (IEC Group IIA) vapors.