

- 1/2" NPT inlet and outlet standard
- Direct acting valve mechanism
- Optional flanged or threaded inlet and outlet connections available
- Inlet gas pressures from 10 PSIG to 200 PSIG
- Set points from -0.1 in.W.C. to 69.2 in.W.C.
- Optional flow plugs to meet specific flow requirements
- Fully field serviceable
- Optional sense line gauges
- System purge and field test capability available
- Conforms with European ATEX Directive 94/9/EC

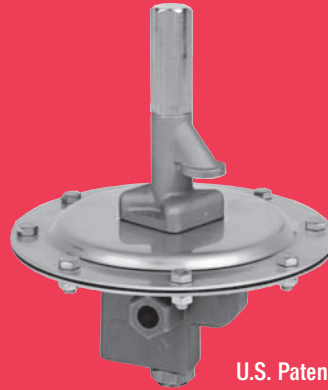

U.S. Patent No. 5,660,204

SERIES 30

Tank Blanketing is an effective means of preventing fires in flammable liquid storage tanks by controlling the formation of explosive vapor / air mixtures. Blanketing minimizes evaporation of the stored product, thus reducing emission levels. Protection from external sources of contamination that may adversely affect the tank's contents is also provided.

The principle involved is quite simple: a blanket or pad of inert gas in the tank's vapor space prevents atmospheric air from entering the tank. The inert gas, usually Nitrogen, is injected, as necessary, into the vapor space in order to maintain a non-flammable atmosphere. The blanketing pressure is usually very low (less than 1 PSIG). Outside air, which contains oxygen, moisture and other contaminants is not permitted to enter the tank. For those applications where the purity of stored product is a major concern, Protectoseal offers optional Pure-Tech cleaning and packaging specifications for the blanketing valves.

This inert gas is admitted only during inbreathing cycles (vacuum cycles). An inbreathing cycle occurs when liquid is being withdrawn from a tank, or when vapors condense in a tank due to a decrease in temperature.

The amount of inert gas required for a specific application is based on the maximum inbreathing demand under conditions of sudden cooling caused by a rain or hail-storm PLUS the maximum emptying rate.

Although Nitrogen is most commonly used for inerting, other gases, including natural gas, may be used in some applications. Depending upon the specific application,

the selection of an inert gas for a particular process is based upon one or more of the following characteristics:

1. Non-flammable in the atmosphere being protected
2. Non-contaminating
3. Chemically inactive
4. Non-toxic
5. Availability for large quantity use
6. Cost

A typical tank blanketing installation is shown in Fig. 1.

The conservation vent (A) is sized to take care of overpressure and vacuum conditions brought about by unforeseen conditions or equipment failures. The pressure setting of the vent is set at a slightly higher setting than the blanketing pressure in the tank but below the maximum pressure the tank can withstand. Similarly, the vacuum pallet is set at a higher vacuum setting than normal operating conditions bring about and below the maximum vacuum pressure the tank could withstand.

Note the placement of the flame arrester (B) to provide additional protection in the event of inert gas failure. An emergency

relief vent (C) is placed on the tank, the pressure setting being slightly above the conservation vent pressure setting.

In designing a tank blanketing system, several important considerations should be evaluated:

1. Inert gas or tank blanketing equipment must be completely reliable and capable of maintaining an adequate supply of inert gas at all times. Equipment breakdown or equipment that is inadequately sized for the job will result in a higher oxygen concentration in the vapor space of the storage tank which would mix with the vapors resulting in the development of a flammable mixture.
2. The inert gas should be introduced into the tank in such a manner that it can be distributed effectively.
3. Contamination of the inert gas from any source must be guarded against. Any inerting system should have suitable devices to hold moisture to an absolute minimum.

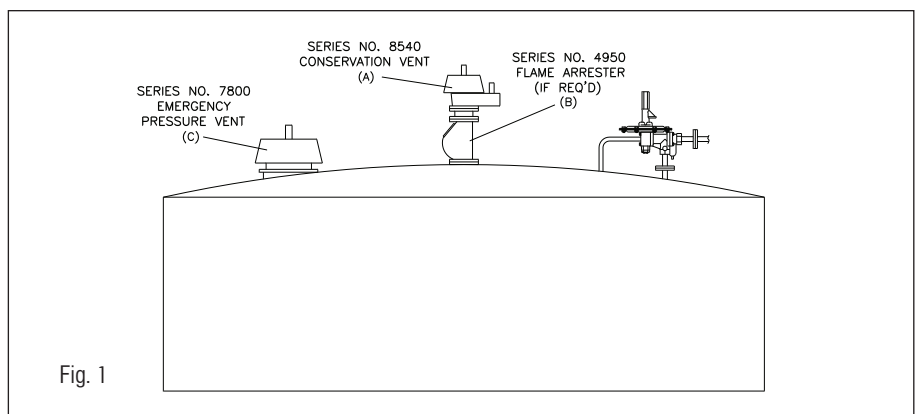

Specifications

PRINCIPLES OF OPERATION

A blanketing valve is used in tank blanketing applications to regulate the pressure of the inert gas layer on top of a tank's stored liquid. The valve senses the pressure of the tank blanket and opens to flow inert gas when pressure drops below the set pressure. The valve closes and stops flow when pressure builds back up to the set pressure. See Fig. 2 and Fig. 3.

The Protectoseal Series 30 Blanketing Valve consists of a direct acting main valve assembly (A) with a movable poppet (B), whose opening and closing is controlled by movement of the sense diaphragm (C) in the pressure sensing chamber (D). Unseating of the poppet allows a flow of inert gas into the tank.

In the preferred configuration, three external connections are required for the operation of the Protectoseal Series 30 Blanketing Valve. The remote sense line (E) runs from the tank to the sense line inlet of the valve. This line provides the controlling pressure to the sensing chamber. It is connected to the tank at a distance far enough from the blanketing valve outlet to insure that it will not be affected by the flow stream of inert gas into the tank. The second line (F) comes from the inert gas supply and connects to the valve inlet. The third external connection (G) joins the valve outlet port to the tank.

The pressure in the tank's vapor space is transmitted through the sense line (E) to the underside of the sense diaphragm (C). This pressure pushes upwards against the combined downward forces of atmospheric pressure (I) on the top side of the sense diaphragm and the setting spring (J). If the pressure in the tank's vapor space is greater than the set point of the valve, determined by the compression of the set spring (J), the sense diaphragm is pushed upward and the valve poppet (B) remains in its closed position (no flow of inert gas into the tank). A decrease in the tank's vapor space pressure results in a corresponding reduced pressure in the sensing chamber (D). Tank pressure less than the valve set point allows downward movement of the sense diaphragm. The stop (K) connected to the diaphragm pushes down on the poppet, causing it to unseat and allowing a flow of inert gas into the tank.

As the tank pressure increases, the sense chamber pressure works to push the diaphragm upwards and the valve poppet is allowed to return to its closed position (aided by the biasing spring (L) under the poppet), stopping the flow of inert gas into the tank.

OPERATING CHARACTERISTICS

The poppet of the Protectoseal Series 30 Tank Blanketing Valve is pressure balanced so that a consistent opening point over the allowable range of blanketing gas supply pressures is realized. The valve functions as a spring loaded valve. Flow through the valve is realized as the pressure in the tanks falls below the set point. As the tank pressure increases above the set point, flow through the device is stopped.

FEATURES & BENEFITS OF THE PROTECTOSEAL BLANKETING VALVE

- Designed specifically for tank blanketing
- ½" NPT female inlet and outlet connections standard
- ANSI 150 lb. or 300 lb. flange connections optional
- Direct acting valve mechanism
- Detects low tank pressure and opens automatically to allow entry of blanketing gas
- Reseals automatically when tank pressure has returned to an acceptable level

- Operates effectively at supply pressures from 10 PSIG to 200 PSIG
- Pressure balanced poppet
- Optional supply line filters available
- Set point not affected by supply pressure.
- A range of flow plug sizes provides the opportunity to tailor flow capacity to tank size
- Field serviceable
- A comprehensive range of materials are offered:
 - Metal parts in 316 Stainless Steel
 - Soft goods (seals & gaskets)* available in Buna-N, Neoprene, Viton®, EDPM, Chemraz® or Kalrez®
- Protectoseal Pure-Tech High Purity Blanketing Valves are available for applications involving high purity products.

On units with Kalrez® or Chemraz® seals and gaskets, the sense diaphragm gasket (Item C) is Buna-N.

PTFE, Viton® and Kalrez® are registered Trademarks of E.I. DuPont de Nemours & Co., Inc.

Chemraz® is a registered Trademark of Green, Tweed & Co., Inc.

MATERIALS OF CONSTRUCTION

Valve Bodies & Components:	STANDARD CUSTOM	316 Stainless Others
Fittings & Hardware:	STANDARD CUSTOM	316 Stainless Others
Springs:		302 Stainless
Seals & Gaskets:	OPTIONS	Buna-N Neoprene, Viton®, EPDM, Chemraz®, Kalrez® & Others
Diaphragm:		FEP Film
Filter:	OPTIONS	Aluminum / Zinc / Polypropylene / Buna-N / Acetal Stainless Steel / Polypropylene / Viton® / Acetal

PRIMARY OPTIONS

Connections:	OPTIONS	½" FNPT inlet & outlet ½", 150# or 300# welded ANSI flanges on inlet / outlet or outlet only
Flow Plugs:	OPTIONS	No flow plug (100% of maximum flow) Flow plugs for 75%, 50%, 25% or maximum flow

Other Options

- Pressure gauges on inlet and / or sense line
- Integral purge on outlet and / or sense line
- Field test accessories
- Single port sensing (see page 6)

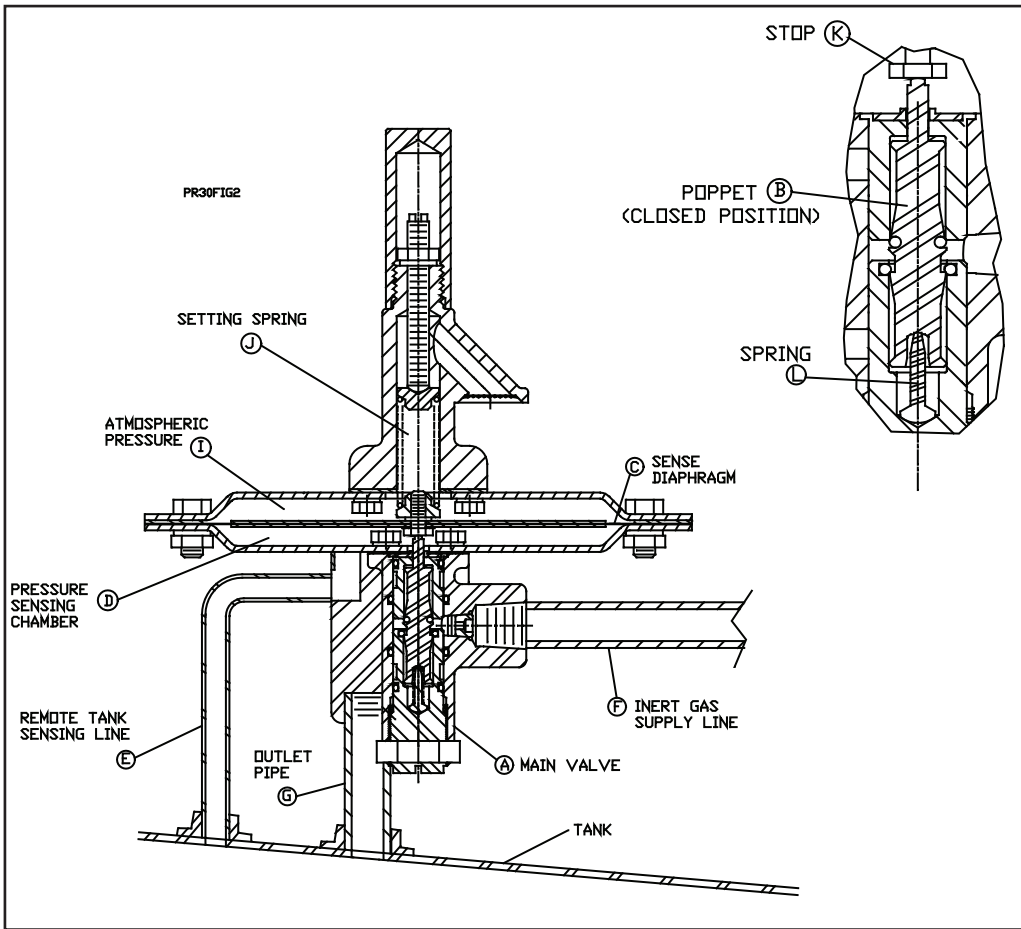

Fig. 2
Blanketing Valve In Closed Position
(Tank Pressure Above Set Point Pressure)

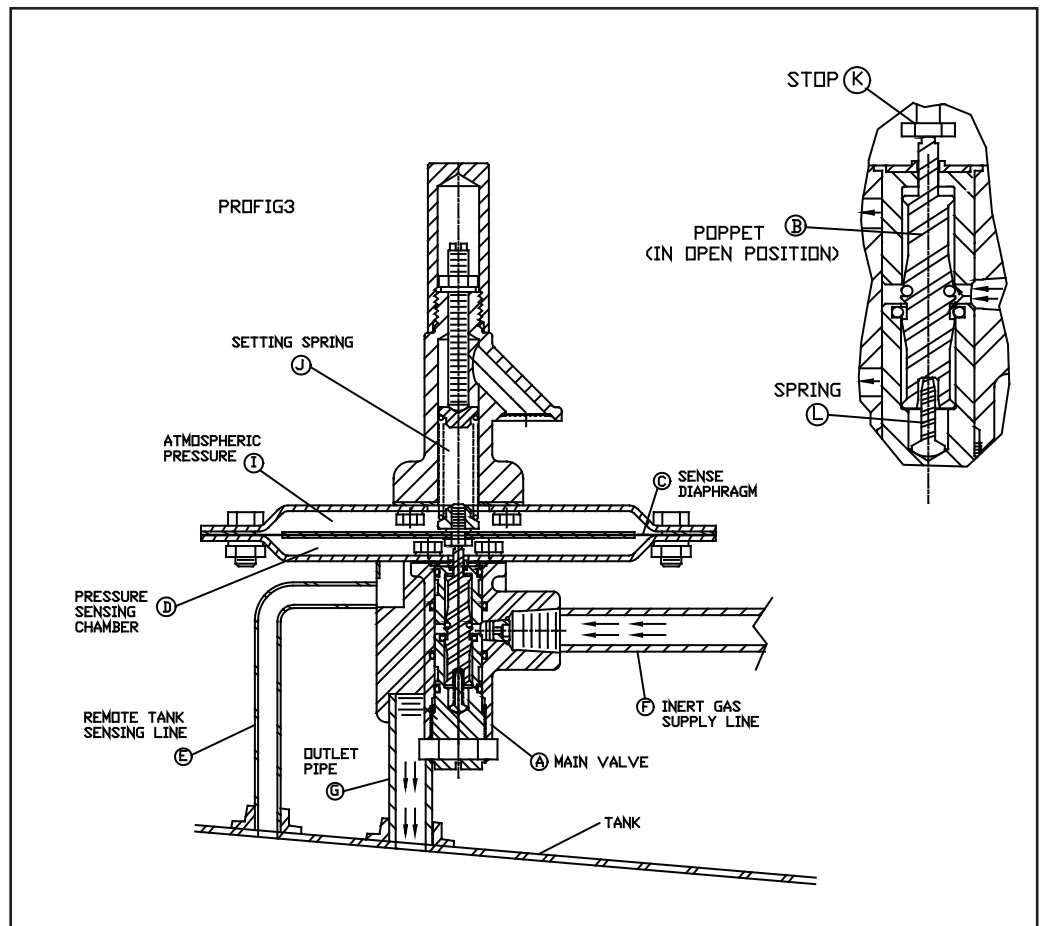

Fig. 3
Blanketing Valve Open and Flowing
(Tank Pressure Below Set Point Pressure)

Specifications

VALVE SIZING TO MEET FLOW REQUIREMENTS

Blanketing valve flow requirements are based upon two factors: 1) the maximum possible emptying rate out of the tank, and 2) the possible effects of cooling during atmospheric changes. Using the total required flow determined from these two factors, the necessary specifications for the blanketing valve can be determined. Follow the three steps below. Steps 1 and 2 are based upon API 2000 recommendations.

STEP 1:

Use Table 1 below to determine the flow required to accommodate the maximum possible emptying rate.

Table 1 – Flow Required to Accommodate Pumping Out

For Maximum Liquid Emptying Rate In :	To Obtain SCFH Air Required Multiply By:	To Obtain N m ³ /h Air Required Multiply By:
US gpm	8.00	0.227
US gph	0.133	0.00379
barrels/hour	5.600	0.159
barrels/day	0.233	0.00662
m ³ /h	35.22	1.00

SCFH is at 60°F and 14.7 psia. Nm³/h is at 0°C and 101.3 kPA (absolute).

STEP 2:

Use Table 2 below to determine the flow required to accommodate the possible effects of atmospheric cooling.

Table 2 – Flow Required to Accommodate Thermal Effects

Barrels	Tank Capacity		Inbreathing Required	
	Gallons	m ³	SCFH	N m ³ /h
60	2,500	10	60	1.7
100	4,200	16	100	2.8
500	21,000	79	500	14
1,000	42,000	159	1,000	28
2,000	84,000	318	2,000	55
3,000	126,000	477	3,000	83
4,000	168,000	636	4,000	110
5,000	210,000	795	5,000	138
10,000	420,000	1,590	10,000	276
15,000	630,000	2,385	15,000	413
20,000	840,000	3,180	20,000	551
25,000	1,050,000	3,975	24,000	661
30,000	1,260,000	4,770	28,000	772
35,000	1,470,000	5,565	31,000	854
40,000	1,680,000	6,360	34,000	937
45,000	1,890,000	7,155	37,000	1,020
50,000	2,100,000	7,950	40,000	1,102
60,000	2,520,000	9,540	44,000	1,212
70,000	2,940,000	11,130	48,000	1,323
80,000	3,360,000	12,720	52,000	1,433
90,000	3,780,000	14,310	56,000	1,543
100,000	4,200,000	15,900	60,000	1,653
120,000	5,040,000	19,080	68,000	1,874
140,000	5,880,000	22,260	75,000	2,067
160,000	6,720,000	25,440	82,000	2,260
180,000	7,560,000	28,620	90,000	2,480

* Interpolate between values as necessary.

STEP 3:

Add the values from Step 1 and Step 2 to determine the total flow requirement. The flows stated in Table 3 will be achieved by a pressure of 1½" W.C. below the set point of the Protectoseal Series 30 Blanketing Valve (no flow plugs).

Table 3 – Flows Through Protectoseal Blanketing Valve

psig	Supply Pressure		Air		Nitrogen		0.6g Natural Gas	
	kPa (g)	kg/cm ² (g)	SCFH	N m ³ /h	SCFH	N m ³ /h	SCFH	N m ³ /h
10	69	0.7	246	6.8	250	6.9	317	8.7
20	138	1.4	345	9.5	351	9.6	445	12.2
40	276	2.8	543	14.9	552	15.2	701	19.3
60	414	4.2	742	20.4	754	20.7	958	26.4
80	552	5.6	941	25.9	957	26.3	1,215	33.4
100	690	7.0	1,140	31.4	1,159	31.9	1,472	40.5
120	827	8.4	1,339	36.9	1,361	37.5	1,728	47.6
140	965	9.8	1,537	42.3	1,563	43.0	1,984	54.6
160	1,103	11.2	1,736	47.8	1,765	48.6	2,241	61.7
180	1,241	12.7	1,935	53.3	1,968	54.2	2,498	68.8
200	1,379	14.1	2,134	58.8	2,170	59.8	2,755	75.9

NOTES: Estimated flow values. Interpolate between values as necessary. SCFH is at 60° F and 14.7 psia. N m³/h is at 0° C and 101.3 kPa (absolute). Optional flow plugs can be used to restrict flow to 75%, 50% or 25% of the flows listed above.

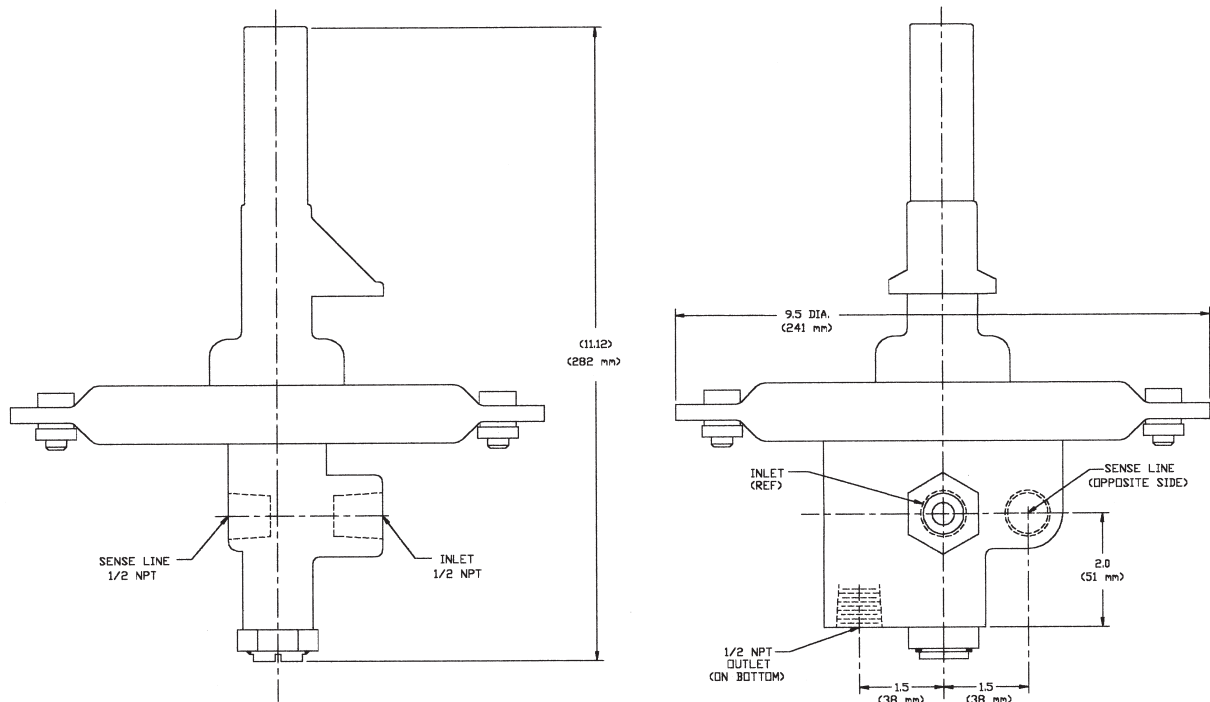

DIMENSIONS

(Dimensions shown are for reference only. Contact Factory for certified drawings.)

SINGLE PORT SENSING

- Single connection mounting
- Eliminates need for separate sense line connection to tank
- Efficient control of tank pressure

If the preferred independent sense line configuration cannot be accommodated, the single port design allows for mounting the blanketing valve with only one tank connection. Tank vapor space pressure sensing and blanketing gas supply are accomplished through a common tank fitting. Outlet tube directs blanketing gas flow past the pressure sensing location in the connection to minimize vapor space pressure sensing errors. A minimum 1" pipe size connection is required. Consult factory for details.

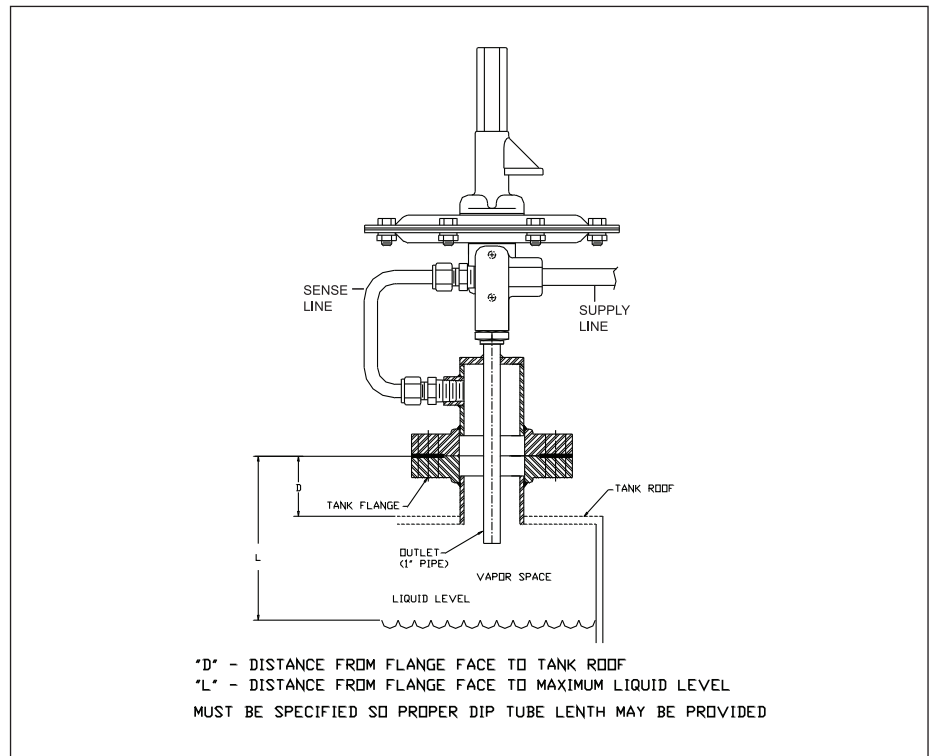

Information to be Placed on the Order Form for Factory Use:

1. Part Number

2. Set Point Pressure in inches WC

3. Supply Pressure in PSIG

Customer: _____

Order Number: _____ Tag Number: _____

Part Number: _____ Special

Set Point Pressure¹: _____ inches WC (convert other units to inches WC for the order form)
 PSIG inches Hg mbar Other _____

Supply Pressure²: _____ PSIG (convert other units to PSIG for the order form)
 kPA kg/cm² bar Other _____

Required Air Flow: _____ SCFH SCFM N m³/h Other _____

Elastomer Type Buna-N Neoprene Viton® EPDM Chemraz® Kalrez®
 Other _____

Inlet Connection: Pipe Size _____
 FNPT 150# Flange 300# Flange
 Other _____

Outlet Connection: Pipe Size _____
 FNPT 150# Flange 300# Flange
 Other _____

Filter: Aluminum/Zinc/Buna-N Stainless Steel 316/Viton®
 Other _____

Flow Capacity: 100% 80% 60% 40% 20% 10%
 Other _____

Pressure Gauge: Not Included Supply Line Gauge Sense Line Gauge
 Other _____

Integral Purge: Not Included Supply Line Gauge Sense Line Gauge
 Other _____

Check Valve: Not Included Included
 Other _____

Field Test: Not Included Included
 Outlet Line 3-Way Valve Sense Line Shut-Off Valve
 Other _____

Options Not Listed Above: _____

¹The blanketing valve is set to OPEN at the set point pressure. If used in conjunction with pressure/vacuum vents or other relieving devices, the following guidelines should be adhered to (all values in inches WC):

Blanketing Valve Set Point	MINIMUM Pressure Vent Set Point	MINIMUM Vacuum Vent Set Point (gauge)
-0.5 to 10.0	2.0 ABOVE Valve Set Point	0.5 BELOW Valve Set Point
10.1 to 20.0	4.0 ABOVE Valve Set Point	For Blanketing Valve Set Points BELOW 0.5 gauge, set Vacuum Vent at least 0.5 gauge BELOW Valve Set Point
20.1 to 30.0	6.0 ABOVE Valve Set Point	
Above 30.0	8.0 ABOVE Valve Set Point	

²Supply pressure limits are 10 PSIG (69 kPa) minimum/200 PSIG (1379 kPa) maximum. Production testing will be done at the given supply pressure. SET POINT RANGES MAY BE VARIED. CONTACT FACTORY FOR SPECIFIC APPLICATIONS OUTSIDE THE STATED GUIDELINES.

PROTECTOSEAL MODEL NO. 30 BLANKETING VALVE NUMBERING SYSTEM

EXAMPLE:

DIGIT:	1	2	3	4	5	6	7	8	9	10	11	12
PART NO. CODE:	F	3	0	B	A	B	A	A	0	0	0	0

1	MATERIAL	F: 316 Stainless Steel K: Same as above with cleaning/packaging to Pure-Tech specifications	8	FLOW CAPACITY	A: 100% (NO PLUG) B: 75% C: 50% D: 25%
2-3	SERIES NO.	30	9	FILTER OPTION (Filters not assembled to valve)	0: No filter 1: 1/2" FNPT aluminum filter 2: 1/2" FNPT stainless steel filter
4	HOUSING DESIGN	B: Investment Cast Body	10	PRESSURE GAUGE OPTION **	0: No gauges 1: Supply line gauge only 2: Sense line gauge only 3: Sense line & supply line gauges
5	CONNECTIONS: (INLET / OUTLET)	A: 1/2" FNPT / FNPT B: 1/2" FNPT / 150# flange C: 1/2" FNPT / 300# flange D: 1/2" 150# flange / 150# flange E: 1/2" 300# flange / 300# flange	11	INTEGRAL PURGE OPTION	0: No purge 1: Outlet line purge only 2: Sense line purge only 3: Outlet line and sense line purge
6	SET POINT PRESSURE RANGE (in inches W.C.)	A: -0.1" including 3.0" B: Above 3.0" including 7.0" C: Above 7.0" including 25.0" D: Above 25.0" including 69.2"	12	FIELD TEST OPTION ***	0: Not included 1: Included 2: Included with 3-way valve for outlet line 3: Included with shut-off valve for sense line 4: Included with 3-way valve for outlet line & shut-off valve for sense line
7	SOFT GOOD MATERIALS SEALS & GASKETS*	A: Buna-N B: Neoprene C: Viton® D: EPDM E: Kalrez® F: Chemraz®			

* On units with Kalrez® or Chemraz® seals and gaskets (option code E or F), the sense diaphragm gasket (Item C) will be Buna-N.

** Stainless steel gauge available (consult factory).

*** Sense line and supply line gauges included. Digit #10 should be option 3.

Viton® and Kalrez® are registered Trademarks of E.I. DuPont de Nemours & Co., Inc. Chemraz® is a registered Trademark of Green, Tweed & Co., Inc.



Wellington Head Office: 90 Sydney St, PO Box 38 720
Petone, Wellington, Tel: 64 4 568 4933, Fax: 64 4 568 4789
Email: sales@liquip.co.nz Website: www.liquip.co.nz