

SERIES 27000, 29000 & 31000

End-of-Line Crimped Metal Flame Arresters



PROTECTOSEAL.

- Series 27000 for NEC Group D, IEC Group IIA Vapors
- Series 29000 for NEC Groups D & C, IEC Groups IIA & IIB3 Vapors
- Series 31000 for NEC Groups D, C & B, IEC Groups IIA, IIB3 & IIC Vapors
- Accurate and consistent element windings
- Low pressure drops, less susceptible to clogging
- Weatherhood easily removed for maintenance
- Available in Carbon Steel & Stainless Steel
- Factory inspected prior to shipment
- Removable element

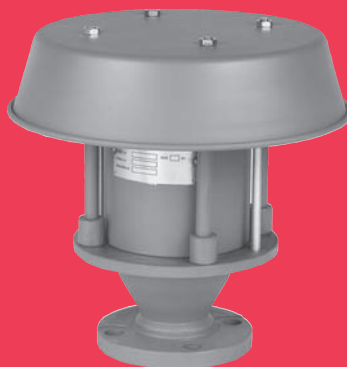

SERIES
27000
29000
31000

OBJECTIVE

The Protectoseal Series 27000, 29000 & 31000, End-of-Line Crimped Metal Flame Arresters are installed where it is necessary to protect against external unconfined deflagrations from entering the tank's vapor space but not necessary to conserve vapor losses. They have been certified for use with the following chemical vapor mixtures as defined in the National Electric Code (NEC) Article 500:

Series 27000 - Suitable for Group D chemical vapors, generally equivalent to International Electrotechnical Commission (IEC) Group IIA.

Series 29000 - Suitable for Groups D & C chemical vapors, generally equivalent to International Electrotechnical Commission (IEC) Groups IIA & IIB3.

Series 31000 - Suitable for Groups D, C & B chemical vapors, generally equivalent to International Electrotechnical Commission (IEC) Groups IIA, IIB3 & IIC.

TECHNIQUE

These arresters are installed on the end of a tank or process vent pipe. Vapors are allowed to escape into the atmosphere and air can be drawn in through the specially designed flame arrester grid assembly. The crimped metal element provides protection from flashback into the tank or process equipment if vapors ignite externally. Unitized crimped metal element provides straight thru flow path, low pressure drop and are less susceptible to clogging.

SPECIAL FEATURES

Sizes Available.

Series 27000 - 2" (DN 50) through 16" (DN 400)

Series 29000 - 2" (DN 50) through 6" (DN 150)

Series 31000 - 2" (DN 50) through 3" (DN 80)

Flanged to mate with 150# ANSI or DIN PN 16 bolting *specifications. Other drilling patterns are also available upon special request.

Easy Inspection and Maintenance. The arrester element is easily removable and interchangeable for inspection, cleaning or replacement.

Precision Manufacturing. The crimped metal arrester element design allows for flexibility in application. The ability to control the size of the element openings is the key to arresting external unconfined deflagration flame fronts. Manufactured under Protectoseal's ISO 9001 Quality System.

Quality Assurance. Each unit is factory inspected to meet Protectoseal's high standards prior to shipment.

PRO-FLOW III® Sizing and Selection Software.

Use PRO-FLOW III® to calculate flame arrester flow requirements in accordance with API 2000, ISO 28300, NFPA 30 and OSHA 1910.106.

CONSTRUCTION

A comprehensive range of materials is offered as shown in the chart below. Other metals, or options can be furnished upon request. Please consult factory for availability.

Series	Housing & Element Housing	Element Winding
C27000	Steel	316 S.S.
C29000	Steel	316 S.S.
C31000	Steel	316 S.S.
F27000	316 S.S.	316 S.S.
F29000	316 S.S.	316 S.S.
F31000	316 S.S.	316 S.S.

All units flanged to mate with 150# raised face ANSI and DIN PN 16 raised face flanges.

DIMENSIONS AND ORDERING INFORMATION

Series No. 27000

Suitable for Group D chemical vapors, generally equivalent to International Electrotechnical Commission (IEC) Group IIA. Such vapors are typically characterized by a maximum experimental safe gap (MESG) of 0.9mm.

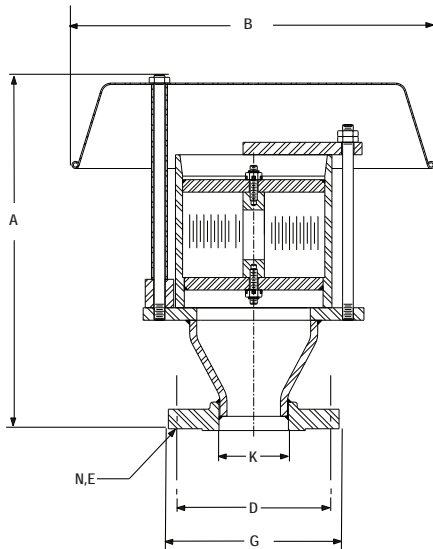

Dimensions shown are for reference only, contact factory for certified drawings.

Cat. No.	Flange K	Height A	Dia. B	B.C. D	Dia. G	Dia. E	Holes N
27002	2"	11"	12 ³ / ₄ "	4 ³ / ₄ "	6"	3/4"	4
27002DN	DN50	279mm	324mm	125mm	165mm	18mm	4
27003	3"	12 ¹³ / ₁₆ "	12 ³ / ₄ "	6"	7 ¹ / ₂ "	3/4"	4
27003DN	DN80	325mm	324mm	160mm	200mm	18mm	8
27004	4"	13 ³ / ₈ "	16 ⁵ / ₁₆ "	7 ¹ / ₂ "	9"	3/4"	8
27004DN	DN100	340mm	414mm	180mm	220mm	18mm	8
27006	6"	17 ³ / ₈ "	27 ¹ / ₂ "	9 ¹ / ₂ "	11"	7/8"	8
27006DN	DN150	441mm	699mm	240mm	285mm	22mm	8
27008	8"	23 ⁷ / ₁₆ "	27 ¹ / ₂ "	11 ³ / ₄ "	13 ¹ / ₂ "	7/8"	8
27008DN	DN200	595mm	699mm	295mm	340mm	22mm	12
27010	10"	29 ¹¹ / ₁₆ "	38 ¹ / ₄ "	14 ¹ / ₄ "	16"	1"	12
27010DN	DN250	754mm	972mm	355mm	405mm	26mm	12
27012	12"	31 ³ / ₄ "	38 ⁵ / ₈ "	17"	19"	1"	12
27012DN	DN300	806mm	981mm	410mm	460mm	26mm	12
27014	14"	35 ⁹ / ₁₆ "	38 ⁵ / ₈ "	18 ³ / ₄ "	21"	1 ¹ / ₈ "	12
27014DN	DN350	903mm	981mm	470mm	520mm	30mm	12
27016	16"	40"	38 ⁵ / ₈ "	21 ¹ / ₄ "	23 ¹ / ₂ "	1 ¹ / ₈ "	16
27016DN	DN400	1016mm	981mm	525mm	580mm	30mm	16

* Please refer to chart on reverse for the available materials of construction.

Series No. 29000

Suitable for Groups D & C chemical vapors, generally equivalent to International Electrotechnical Commission (IEC) Groups IIA & IIB3. Such vapors are typically characterized by a maximum experimental safe gap (MESG) of 0.9mm (Group D) and 0.65mm (Group C).

Cat. No.	Flange Size K	Height A	Dia. B	B.C. D	Dia. G	Dia. E	Holes N
29002	2"	12 ¹ / ₂ "	12 ³ / ₄ "	4 ³ / ₄ "	6"	3/4"	4
29002DN	DN50	318mm	324mm	125mm	165mm	18mm	4
29003	3"	14 ⁵ / ₁₆ "	12 ³ / ₄ "	6"	7 ¹ / ₂ "	3/4"	4
29003DN	DN80	364mm	324mm	160mm	200mm	18mm	8
29004	4"	14 ⁷ / ₈ "	16 ⁹ / ₁₆ "	7 ¹ / ₂ "	9"	7/8"	8
29004DN	DN100	378mm	421mm	180mm	220mm	18mm	8
29006	6"	18 ¹³ / ₁₆ "	27 ¹ / ₂ "	9 ¹ / ₂ "	11"	7/8"	8
29006DN	DN150	478mm	699mm	240mm	285mm	22mm	8

* Please refer to chart on reverse for the available materials of construction.

Series No. 31000

Suitable for Groups D, C & B chemical vapors, generally equivalent to International Electrotechnical Commission (IEC) Groups IIA, IIB3 & IIC. Such vapors are typically characterized by a maximum experimental safe gap (MESG) of 0.9mm (Group D), 0.65mm (Group C) and 0.29mm (Group B).

Cat. No.	Flange Size K	Height A	Dia. B	B.C. D	Dia. G	Dia. E	Holes N
31002	2"	12 ¹ / ₂ "	12 ³ / ₄ "	4 ³ / ₄ "	6"	3/4"	4
31002DN	DN50	318mm	324mm	125mm	165mm	18mm	4
31003	3"	14 ⁵ / ₁₆ "	12 ³ / ₄ "	6"	7 ¹ / ₂ "	3/4"	4
31003DN	DN80	364mm	324mm	160mm	200mm	18mm	8

* Please refer to chart on reverse for the available materials of construction.