



**THIS IS CONFIDENTIAL INFORMATION.**  
**THIS DRAWING AND DESIGN IS THE PROPERTY OF LIQUIP INTERNATIONAL PTY LIMITED.**  
**IT MUST NOT BE COPIED OR REPRODUCED IN ANY WAY WHATSOEVER AND/OR PASSED ON**  
**TO ANY THIRD PARTY WITHOUT WRITTEN AUTHORITY.**

LIQUIP INTERNATIONAL PTY LIMITED - ENGINEERING DEPARTMENT - 13 HUME RD SMITHFIELD SYDNEY NSW AUSTRALIA 2164  
PH: +61 2 9725 9000 FAX: +61 2 9609 4739 EMAIL: [engineering@liquip-nsw.com.au](mailto:engineering@liquip-nsw.com.au)

## APIRC

### DATA SHEET

PART N°: APIRC

- TITLE:** Drybreak coupler for gravity discharge.
- PURPOSE:** A drybreak coupler intended for gravity discharge only to fit API standard bottom loading adaptors. Suitable for unloading rail cars or use on jumper hoses to pumping systems. Lightweight simple & inexpensive option to standard API bottom loading coupler.
- OPERATION:** Cam levers securely clamp the coupler onto API adaptor. Opening the operating handle will open both poppets on the coupler and adaptor. There are no interlocks on the operating handle but a detent notch retains handle in open or closed position.
- DISMANTLE:** Remove R-Clip. Handle and poppet assembly will drop out. Remove four cap screws only to replace seal.
- VARIANTS:** None
- MATERIALS OF CONSTRUCTION:**
- |                        |                   |
|------------------------|-------------------|
| Body poppet and handle | - Aluminium       |
| Operating Shaft        | - Stainless Steel |
| Seals                  | - Viton           |
- MOUNTING:** Screw any size camlock fittings into 100mm BSP thread.
- WEIGHT:** 4.3kg.
- TECHNICAL DATA:**
- Maximum coupling pressure 350kPa.
  - Product retention to 500kPa.
  - 100mm BSP female thread outlet.
  - 100mm bore throughout.
- ASSOCIATED EQUIPMENT:**
- Screw in camlock fittings.
  - Fits all API adaptors made to RP1004

*Overall dimensions shown on the drawing overleaf.*



**THIS IS CONFIDENTIAL INFORMATION.**  
**THIS DRAWING AND DESIGN IS THE PROPERTY OF LIQUIP INTERNATIONAL PTY LIMITED.**  
**IT MUST NOT BE COPIED OR REPRODUCED IN ANY WAY WHATSOEVER AND/OR PASSED ON**  
**TO ANY THIRD PARTY WITHOUT WRITTEN AUTHORITY.**

LIQUIP INTERNATIONAL PTY LIMITED - ENGINEERING DEPARTMENT - 13 HUME RD SMITHFIELD SYDNEY NSW AUSTRALIA 2164  
 PH: +61 2 9725 9000 FAX: +61 2 9609 4739 EMAIL: engineering@liquip-nsw.com.au

LIQUIP

APIRC

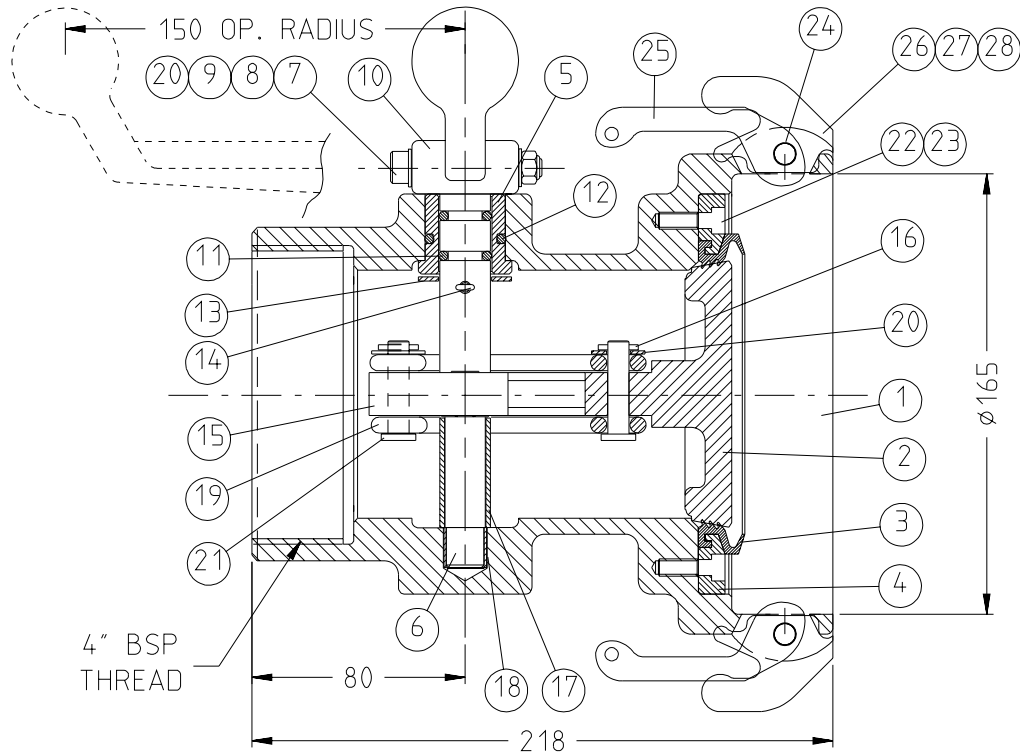

ITEM	PART NO	DESCRIPTION	QTY	MATERIAL
1	APIRC-1	BODY API RAILCAR DRYBREAK	1	ALUMINIUM
2	APINZ-2	POPPET PISTON	1	ALUMINIUM
3	4534	COMBINATION SEAL	1	VITON
4	APINZ-4	RETAINING RING FOR SEAL	1	ALUMINIUM
5	APINZ-5	BUSH	1	ACETAL
6	APINZ-6	OPERATING SHAFT	1	ST STEEL
7	0717	CAPSCREW	1	Z/P STEEL
8	0149	NUT NYLOC	1	Z/P STEEL
9	4415	SPRING HANDLE	1	Z/P STEEL
10	APINZ-7	OPERATING HANDLE	1	ALUMINIUM
11	0235	O-RING	2	VITON
12	4501	O-RING	1	NITRILE
13	5311	WASHER FLAT	1	ST STEEL
14	0945	R-CLIP	1	ST STEEL
15	API513-7	ECCENTRIC CAM	1	ST STEEL
16	0763	SPLIT PIN	2	Z/P STEEL
17	APINZ-8	SPACER TUBE	1	ST STEEL
18	5607	TETRA BEARING	1	TEFLON
19	4425	S SPRING	2	SPRING STEEL
20	0101	WASHER FLAT	4	Z/P STEEL
21	4830	CLEVIS PIN	2	Z/P STEEL
22	4831	CAPSCREW	4	Z/P STEEL
23	4354	WASHER SPRING	4	Z/P STEEL
24	API-DC-3	PIN CAMLOCK	2	BRASS
25	CLC3.0-2	LEVER CAMLOCK	2	BRASS
26	4438	CAMLOCK RETAINER CLIP	2	ST STEEL
27	4440	WASHER SPRING	2	Z/P STEEL
28	4334	WASHER FLAT	2	Z/P STEEL

X200996

Issue: E

METERS - VALVES - VENTS - MANHOLES - PUMPS - HOSEREELS - OVERFILL PROTECTION - LOADING ARMS - ELECTRONIC DIPSTICKS



Wellington Head Office: 90 Sydney St, PO Box 38 720

Petone, Wellington, Tel: 64 4 568 4933, Fax: 64 4 568 4789

Email: sales@liquip.co.nz Website: www.liquip.co.nz