



EZ-8 & EZ-8 METHANOL FUEL PUMP

OWNER'S MANUAL



DO NOT RETURN THIS PRODUCT TO THE STORE!

Please contact Great Plains Industries, Inc. before returning any product. If you are missing parts, or experience problems with your installation, contact our **Customer Support Department**. We will be happy to assist you.



800-835-0113,
316-686-7361

or

email: gpi-sales@gplains.com

Check out the [Great Plains Industries, Inc. YouTube](#) channel to see Installation and Troubleshooting videos for the EZ-8 Fuel Transfer Pump.

TABLE OF CONTENTS

General Information.....	2
Safety Instructions	2
Parts & Service	3
Tools Needed.....	3
Contents Checklist.....	3
Installation	4
Operation.....	6
Maintenance	6
Troubleshooting.....	6
Specifications	8
Illustrated Parts List - EZ-8 / EZ-8 Methanol	9
Warranty.....	12

To the owner...

Congratulations on receiving your GPI® Fuel Transfer Pump. We are pleased to provide you with a system designed to give you maximum reliability and efficiency.

Your fuel pump is engineered, tested, and approved for use with gasoline blends, diesel fuel blends and kerosene (and methanol for the EZ-8 Methanol model). Please take all due precautions when handling these flammable liquids. Your safety is important to us.

Also, to assure the longest possible service life, it is important that you follow the operation and maintenance procedures outlined in this manual. We are proud to provide you with a quality product and dedicated support. Our commitment, together with your conscientious use, will ensure years of safe, dependable service from your fuel pump.

Victor Lukic, President
Great Plains Industries, Inc.



GENERAL INFORMATION

The purpose of this manual is to assist you in installing, operating and maintaining your GPI EZ-8 or EZ-8 Methanol 12-volt DC pump, with manual nozzle.

NOTE: *This pump is not intended for use with an automatic nozzle.*

An automatic bypass valve prevents pressure build up when the pump is on with the nozzle closed. To avoid motor damage, do not run the pump more than 5 minutes with the nozzle closed.

The rated duty cycle of this pump is **15 minutes ON** and **30 minutes OFF**. Allow the pump to cool for 30 minutes.

The EZ-8 is designed for use with gasoline (up to 15% alcohol blends such as E15), diesel fuel (up to 20% biodiesel blends such as B20) and kerosene only. Do not use this pump for dispensing any fluids other than those for which it was designed. Doing so may damage pump components and **will void the warranty**.

The EZ-8 Methanol pump is specifically designed for use with methanol and ethanol. The pump is also compatible with gasoline, diesel fuel (up to 20% biodiesel blends such as B20) and kerosene. Do not use this pump for dispensing any fluids other than those for which it was designed. Doing so may damage pump components and **will void the warranty**.



This pump is designed to operate on a typical 12-volt DC automotive electrical system. The pump is designed to operate with 12-volts DC at the motor leads, and the ratings are determined at that voltage. Performance may vary due to length of power cord, battery condition, or output from vehicle charging system affecting system voltage.

Do not leave the system running without fluids. “Dry running” can damage the pump. If the system fails to deliver fuel after 15 to 20 seconds, turn the system off and refer to the Troubleshooting Section.

Do not completely empty the fuel tank, as contaminants from the bottom of the tank may enter the pump.

SAFETY INSTRUCTIONS

Observe all safety precautions concerning safe handling of petroleum fuels.

To ensure safe operation, all fuel transfer systems must be properly grounded. Proper grounding means a continuous metal-to-metal contact from one component to the next, including tank, tank adapter, pump, meter, filter, hose, and nozzle. Care should be taken to ensure proper grounding during initial installation and after any service or repair procedures. For your safety, please take a moment to review the warnings below.

- To prevent physical injury, observe precautions against fire or explosion when dispensing fuel. Do not operate the system in the presence of any source of ignition including running or hot engines, lighted cigarettes, or gas or electric heaters.
- Observe precautions against electrical shock when operating the system. Serious or fatal shock can result from operating electrical equipment in damp or wet locations.
- Inspect external pump wiring regularly to make sure it is correctly attached to the battery. To avoid electrical shock, use extra care when connecting the pump to power.
- Avoid prolonged skin contact with petroleum fuels. Use protective goggles, gloves, and aprons in case of splashing or spills. Change saturated clothing and wash skin promptly with soap and water.
- Observe precautions against electrical shock when servicing the pump. Always disconnect power before repairing or servicing. Never apply electrical power to the system when any of the coverplates are removed.
- If using solvent to clean pump components or tank, observe the solvent manufacturer’s recommendations for safe use and disposal.

PARTS & SERVICE

In order to preserve the UL Listing for the motor, do not attempt to service the motor. For products serviced outside the factory, the UL nameplate must be defaced to indicate that the equipment may no longer meet the requirements for UL Listing. This does not apply to products serviced outside the factory under the UL program for Rebuilt Motors for Use in Hazardous Locations.

For warranty consideration, parts, or other service information, please contact your local distributor or the GPI Customer Service Department in Wichita, Kansas U.S.A., during normal business hours at:

1-800-835-0113

To obtain prompt, efficient service, always be prepared with the model number of your pump, the serial number or manufacturing date code of your pump, and part descriptions and numbers.

For warranty work, always be prepared with your original sales slip or other evidence of purchase date.

Please contact GPI before returning any parts. GPI can inform you of special requirements you will need to follow.

CAUTION: Do not return the pump or parts without prior approval from the GPI Customer Service Department. Due to strict government regulations, GPI cannot accept parts unless they have been drained and cleaned.

TOOLS & SUPPLIES NEEDED

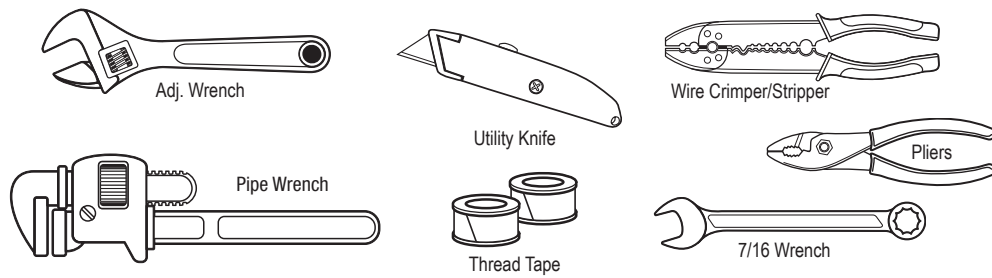

Before proceeding with installation determine if the pump will be temporarily or permanently wired to your vehicle.

Temporary Wiring

Alligator Clamps
(Not included)

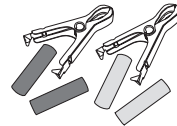

Permanent Wiring

Terminal Post Rings
(Not included)

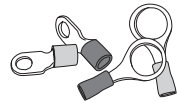

CONTENTS CHECKLIST

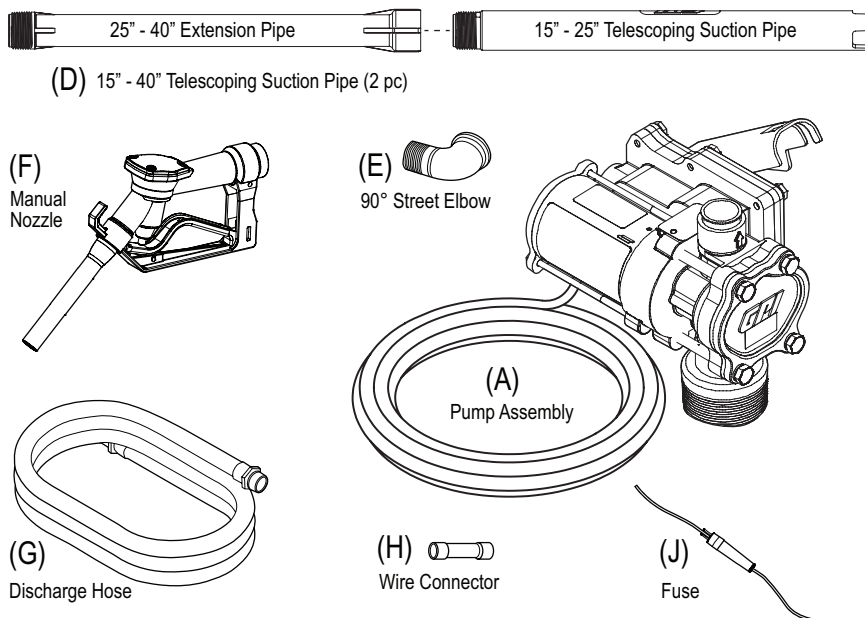

EZ-8 Model with Easy Spin Collar

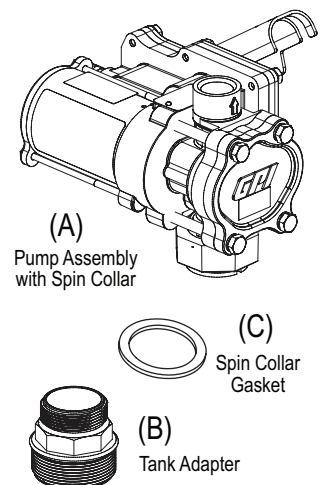

INSTALLATION

INSTALL PUMP ON TANK

Step 1

NOTE: For EZ-8 with Spin Collar, wrap both threaded ends of the tank adapter (B) 3 or 4 times with thread tape, and then insert tank adapter into tank (Figure 1).

NOTE: Aluminum Tank Installation - To prevent thread galling of aluminum fittings, always prepare the threads for assembly using an anti-seize compound such as Loctite® 567TM, Hernon® Dripstop® 940, or equivalent.

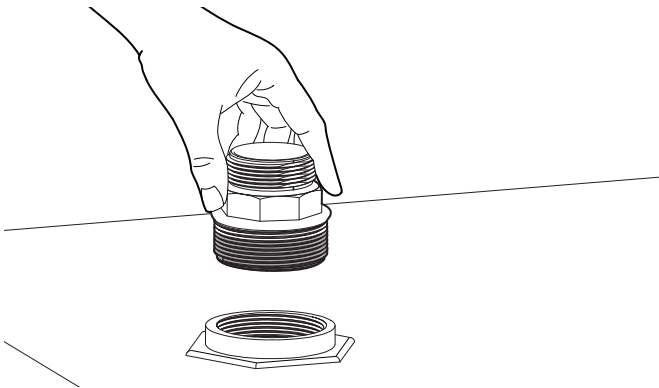

Figure 1

Step 2

Using pliers, remove the plastic plug from inlet port on bottom of pump. **Note: For EZ-8 models with Spin Collar, place the spin collar gasket (C) into the inlet fitting on bottom of pump (see Figure 2).**

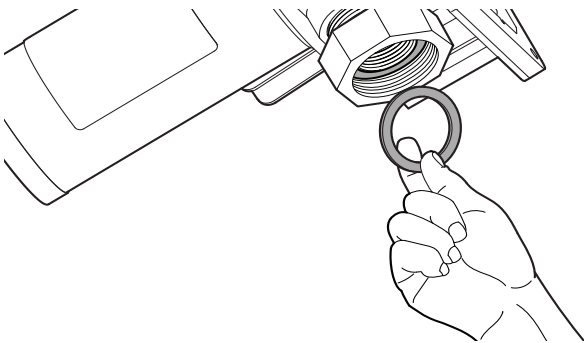

Figure 2

Step 3

Wrap the threaded end of the telescoping suction pipe (D) with 3 to 4 turns of thread tape.

Note: If your tank is 15" - 25" deep, do not use the included suction pipe extension; if your tank is 25" - 40" deep, attached the suction pipe extension.

Step 4

Thread the suction pipe into the pump's inlet fitting and tighten until snug.

Step 5

Before installing the pump on the tank, clean the tank interior of all dirt and foreign material

Step 6

Fully extend the telescoping portion of the suction pipe. Carefully insert suction pipe into the tank opening, position pump and tighten securely.

NOTE: Be sure tank is properly vented (Vent cap sold separately) (Figure 3).

NOTE: For EZ-8 with Spin Collar, securely tighten spin collar.

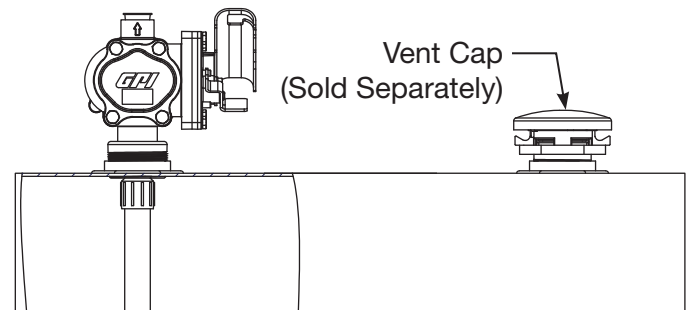

Figure 3

INSTALL ELBOW, HOSE & NOZZLE

Step 1

Seal the threaded ends of the 90° street elbow (E) and both ends of the discharge hose (G) with 3 to 4 turns of thread tape.

Step 2

Using pliers, remove the plastic plug from outlet port on top of pump. Thread the 90° street elbow into outlet port and tighten securely.

Step 3

Thread one end of hose into the 90° street elbow and tighten securely. Thread opposite end of hose into nozzle (F) and tighten securely (Figure 4).

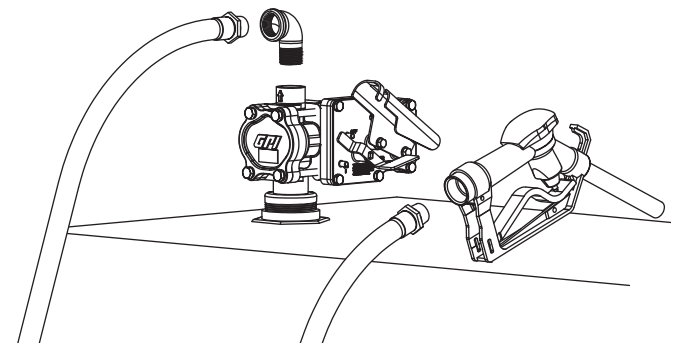

Figure 4

Step 4

Place the nozzle into the nozzle holder on the end of the pump motor housing. Note that the nozzle cannot be placed in the holder unless the pump switch is OFF (Figure 5).

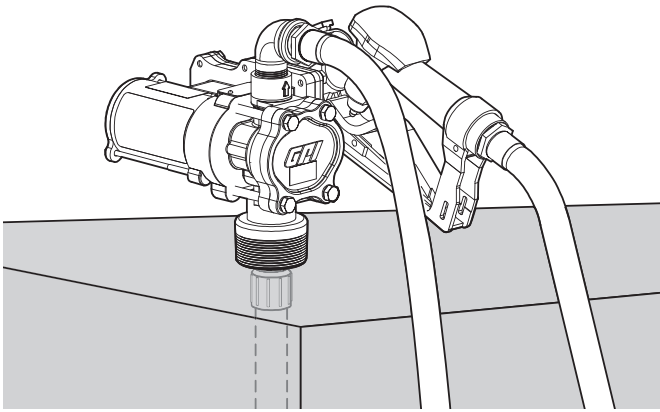

Figure 5

CONNECT TO A POWER SOURCE

Please consult the Owner's Manual for your vehicle before proceeding.

NOTE: The pump is designed for use with a 12-volt power source. Do not attempt installation on a 24-volt or 115-volt system.

WARNING: Do not attempt to power the pump from vehicle wiring smaller than 14 gauge, such as the cigarette lighter wire, as these thin wires could overheat and cause a fire.

NOTE: This pump is pre-wired for installation in CLASS I, DIVISION 2 locations such as portable fuel tanks, trailers, etc. Connection to a battery will depend upon the application.

WARNING: If pump is to be installed in a CLASS I, DIVISION I location please contact GPI for the appropriate product.

Verify switch is in OFF position, then route the electrical wires to the source of the vehicle power system. Be sure to support the wires as necessary and protect them from sharp edges, heat or anything that could damage the wires.

Step 5

If the power cord provided is too long, using a utility knife, cut to desired length. Using utility knife, carefully strip 3 to 4 inches (7.5 to 10 cm) of outer insulation from end of power cord. **DO NOT CUT INNER WIRES.** Next, strip ¼ inch (0.6 cm) of insulation from the black and red power cord wires.

Step 6

For a negative ground system, first disconnect the vehicle's ground wire, and then wire as follows: Insert one end of the fuse (J) into the wire connector (H) and crimp. Insert the red power cord wire into the other end of the wire connector and crimp. Make sure the fuse is positioned outside of hazardous areas and as close to the battery as possible. Make a solid electrical connection to the grounded side of the battery with the remaining black wire. Connecting directly to the battery terminal or the end of the battery cable is recommended.

Step 7

For temporary wiring: Connect the red and black power cords to alligator clamps (not included) (Figure 6).

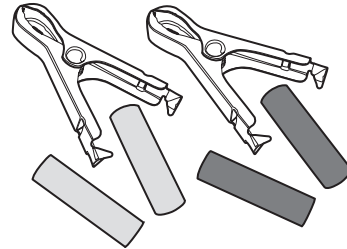

Figure 6

Step 8

For permanent wiring: Connect the red and black power cords to terminal post rings (not included) (Figure 7).

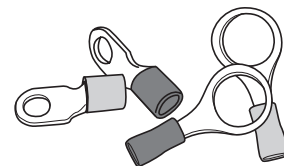

Figure 7

Step 9

Check all connections to make sure they are connected per instructions and all electrical codes. The installation is now complete.

OPERATION

Always follow safety precautions when operating this equipment. Review the Safety Instructions. Before each use, repair leaks around seals or connections. Make sure hoses are in good condition and connections are tight. Make sure the work area is dry. **Make sure the pump is properly grounded.** Repair any corroded or damaged wiring before use. Ensure the tank contains enough fuel. Make sure the fuel is not contaminated with debris. Tighten loose tank lids regularly.

To Dispense Fuel

Turn on the pump by removing the nozzle from the holder and pushing up the switch lever. Insert the nozzle into the receiving tank and squeeze the handle to start fuel flow. When done, release the nozzle handle, turn the pump off, and return the nozzle to its holder.

This pump is designed to be self-priming. If fuel is not delivered within 15 to 20 seconds, turn the pump off and refer to priming information in the Troubleshooting Section.

An automatic bypass valve prevents pressure build up when the pump is on with the nozzle closed. To avoid pump damage, do not run the pump more than 5 minutes with the nozzle closed.

After running the pump for a maximum of 15 minutes, allow it to cool for 30 minutes.

Auxiliary Temperature-Limiting Device

The motor is provided with an internal auxiliary temperature-limiting device. Excessive motor heat can trip the device. It resets automatically after the motor has cooled.

MAINTENANCE

This pump is designed for minimum maintenance. Motor bearings are sealed and require no lubrication. Inspect the pump and components regularly for fuel leaks and make sure the hose and power cord are in good condition. Keep the pump exterior clean to help identify leaks.

Do not use this pump for water, chemicals or herbicides. Dispensing any fluid other than that listed in this manual will damage the pump. Use of the pump with unauthorized fluids will void the warranty.

TROUBLESHOOTING

Always disconnect power before repairing or servicing the pump. Never apply power to the system when any coverplate is removed.

MOTOR DOES NOT RUN

- Auxiliary temperature-limiting device tripped. Turn pump switch off. Allow motor to cool. Device resets automatically. Try again.
- Fuse blown. Inspect fuse in fuse holder. If blown, replace (See Figure 8).

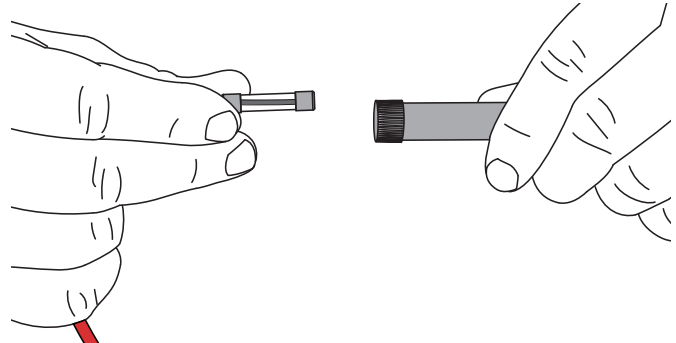

Figure 8

- Switch defective. Remove electrical coverplate and inspect switch (Figure 9). Replace if necessary.

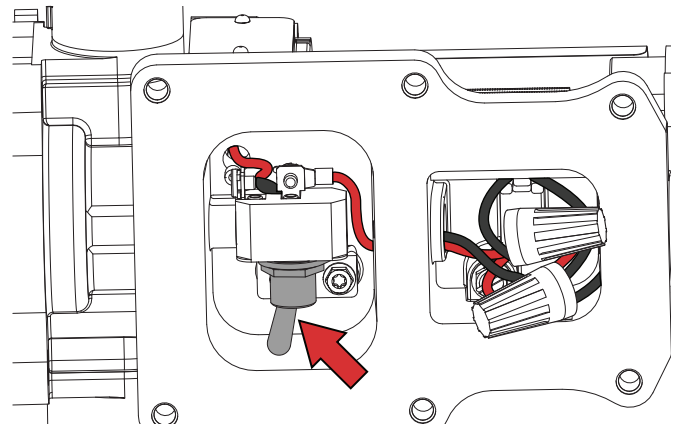

Figure 9

- Switch or electrical connection faulty. Inspect for defective wiring or switch, or improper electrical connections. Replace as necessary.
- Motor burned out. Inspect and replace as necessary.

MOTOR RUNS BUT DOES NOT PUMP FLUID

- Fuel level low. Fill tank.
- Strainer clogged or defective. Inspect and clean as required (See Figure 10).

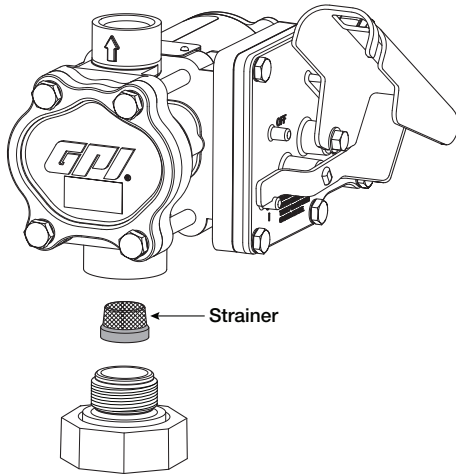

Figure 10

- Suction pipe clogged, damaged, or missing. Remove pump from tank. Inspect suction pipe. Clean or replace, as necessary.
- Gear coverplate or O-ring damaged. Remove and inspect the coverplate and O-ring (See Figure 11). Replace as necessary.

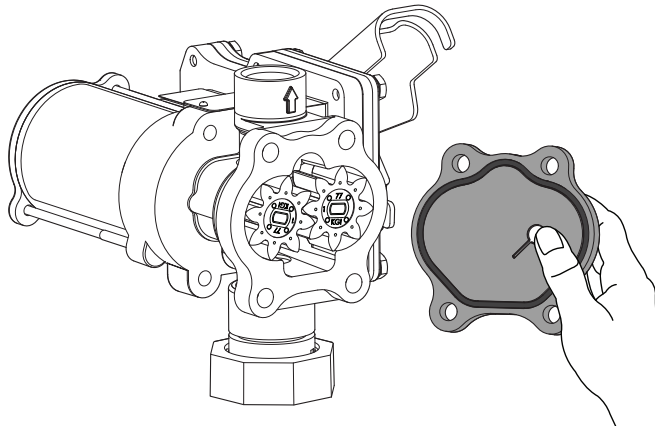

Figure 11

Bypass poppet O-ring worn, missing or dirty. Inspect the O-ring. Replace as necessary. To remove the o-ring, first remove the gear coverplate and drive gears. Using an index finger, push the poppet assembly downward through the outlet port, and then remove the o-ring using an o-ring puller (See Figure 12).

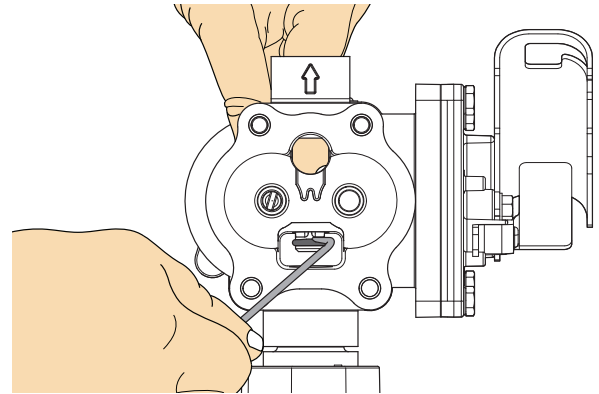

Figure 12

- Bypass poppet binding or damaged. Remove the bypass poppet, spring, and O-ring (Figure 13). Clean cavity. Inspect and replace as necessary.

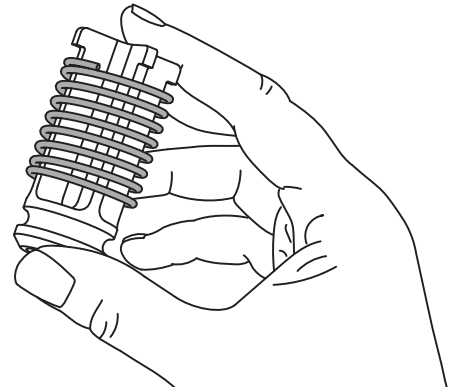

Figure 13

- System air leak. Tighten all pump fittings and connections. Inspect suction pipe for leaks or damage.
- Poor connections or low voltage. Make sure electrical connections are secure. Also check battery voltage.
- Motor running backwards due to incorrect polarity (See Figure 14). Connect red wire to positive (+) ungrounded side of battery.

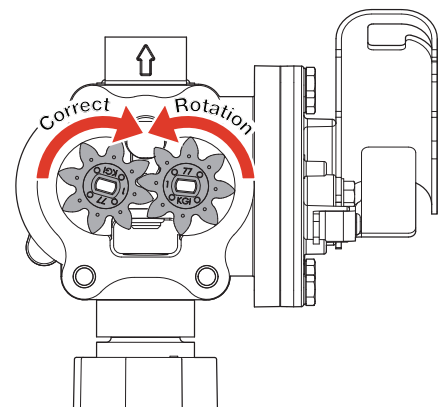

Figure 14

LOW FLOWRATE

- Fuel tank empty. Fill tank.
- Strainer partially clogged. Inspect and clean as required.
- Suction pipe clogged or damaged. Remove pump from tank. Inspect suction pipe. Clean or replace.
- Suction pipe too close to tank bottom. Suction pipe must have at least 1/2 in. (1.2 cm) clearance from bottom of tank.
- System air leak. Tighten all pump fittings and connections. Inspect suction pipe for leaks or damage. Replace as necessary.
- Poor connections or low voltage. Make sure electrical connections are secure. Also check battery voltage.

MOTOR STALLS WHEN OPERATING IN BYPASS MODE

- Bypass poppet binding or damaged. Remove the bypass poppet, spring, and O-ring. Clean cavity. Inspect components and replace as necessary.
- Wiring defective. Use instructions in the Installation Section to ensure proper electrical connections.
- Gears locked. Remove gear coverplate and inspect gears and drive key. Make sure gears turn freely with the key removed. Replace, if worn.
- Motor defective. Inspect and replace as necessary.

SWITCH FAILS TO OPERATE MOTOR

- Switch or electrical connections faulty. Inspect for blown fuse, defective wiring or switch, or improper electrical connections. Replace as necessary.
- Motor burned out. Inspect and replace as necessary.

RAPID OVERHEATING OF MOTOR

- Fuel level low. Fill tank.
- Duty cycle too long. Pump operation should not exceed the standard duty cycle of 15 minutes on and 30 minutes off. Allow the pump to cool for 30 minutes.

- Running too long in bypass mode. Limit bypass operation to 5 minutes.
- Strainer clogged. Inspect and clean as required.
- Suction pipe clogged or damaged. Remove pump from tank. Inspect suction pipe. Clean or replace as necessary.

SPECIFICATIONS

Applications for EZ-8	Low viscosity petroleum fuels:
	Gasoline (up to 15% alcohol blends such as E15)
	Diesel fuel (up to 20% biodiesel blends such as B20)
	Kerosene
Applications for EZ-8 Methanol	Designed for permanent mounting on vented storage tanks
	Methanol and Ethanol
	Gasoline
	Diesel fuel (up to 20% biodiesel blends such as B20)
Pump housing	Kerosene
	Lightweight, corrosion-resistant, cast aluminum body.
Performance	
Pump rate	Up to 8 GPM (30 LPM)
Duty cycle	15 minutes ON, 30 minutes OFF
Suction lift	Manual nozzle: Up to 5.5 ft. (1.7m)
Operating temperature	-20°F to +125°F (-29°C to +52°C)
Operating pressure	15 PSI
Electrical specifications	Input: 12-volt DC
	Current draw: 11 amp
	Motor: 2100 RPM, UL Listed to UL Canadian Standards, 1/10 HP (75 watts)
Mechanical connections	Bung: 2 in. NPT, Inlet: 3/4 in. NPT, Outlet: 3/4 in. NPT
Accessories	5/8 in. x 10 ft. (3.0m) Buna-N electrically conductive discharge hose
	Standard 3/4 in. manual unleaded nozzle
	Cord: 15 ft. (4.6m), 14/2 gauge
	Fuse: 20 amp
Shipping weight	Strain relief grip
	16.0 lbs. (7.5 kg) with manual nozzle

ILLUSTRATED PARTS LIST - EZ-8 & EZ-8 METHANOL

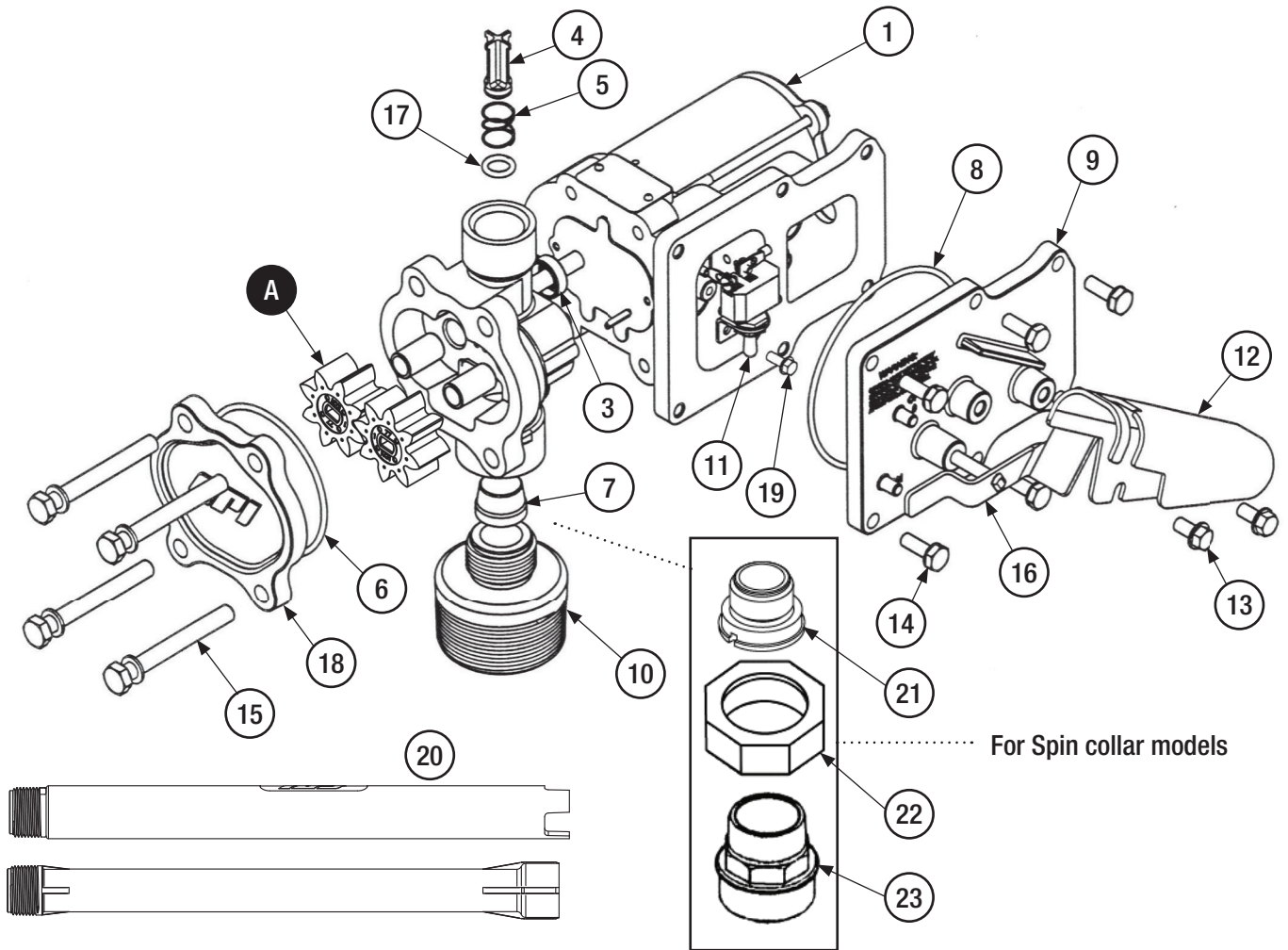

Individual Parts

Item No.	Part No.	Description	Req'd.
1	137078-501	Motor, 12-Volt	1
2	904004-2	Screw, Hex Head Cap.....	4 ea.
3	11002502	Motor Shaft Seal.....	1
4	137031-01	Bypass Poppet.....	1
5	137039-06	Spring, Bypass Poppet	1
6	901003-76	O-Ring.....	1
7	123038-1	Inlet Strainer	1
8	901003-70	O-Ring.....	1
9	137014-01	Switch Coverplate.....	1
10	137030-05	Inlet Fitting (Bung adapter).....	1
11	902007-530	Switch	1
12	110360-02	Nozzle Cover.....	1
13	904006-86	Tapping Screw.....	2 ea.
14	904002-23	Sems Screw	6 ea.
15	904007-65	Washer, Flat	4 ea.
16	137007-01	Switch Lever Assy.....	1
17	901003-77	O-Ring.....	1
18	137012-01	Gear Coverplate	1
	137012-02	Gear Coverplate, ENP (For Spin collar models).....	1
19	904003-84	Screw, Switch Bracket.....	1
20	110241-01	Telescoping Suction Pipe	1
21	13706702	Inlet Fitting, ENP (Bung adapter).....	1
22	110158-1	Spin Collar (Union ring).....	1
23	110037-1	Bushing, Tank Bung Adapter.....	1

Kits and Accessories

Item No.	Part No.	Description
	110037-1	Bushing, Tank Bung Adapter (Spin Collar Model)
	13750006	Drive Key Kit (includes Drive Key)
	13750001	Fuse Holder Kit (includes Fuse Holder, Fuse, Wire)
	110032-1	Gasket, Union Ring (Spin Collar Model)
	13750004	Gear Coverplate Kit (includes Gear Coverplate, O-Ring #6)
A	13750003	Gear Kit (includes 2 Gears & Drive Key) or (Kit B) For pumps mfg. on or before Jan. 8, 2016
A	137500-13	Gear Kit (includes 2 Gears, coverplate, #6 o-ring) or (Kit C) For pumps mfg. Jan. 15, 2016 or later
	136157-01	Hose, (3/4-inch NPT x 5/8 x 10 ft.)
	110155-1	Nozzle, Manual 3/4 in., Unleaded
B	13750005	Overhaul Kit (includes Drive Key, Motor Shaft Seal, 2 Gears, O-Ring #8, O-Ring #6, O-Ring #18) For pumps mfg. on or before Jan. 8, 2016
C	137500-14	Overhaul Kit (includes Motor Shaft Seal #3, 2 Gears, O-Ring #8, O-Ring #6, O-Ring #17, switch lever shaft seal) For pumps mfg. Jan. 15, 2016 or later
	110412-15	Power Cord, 14 ga. x 15 ft. (4.6 m)
	904002-17	Strain Relief Sealing Grip
	13750002	Wet Seal Kit (includes Motor Shaft Seal, O-Ring #6, O-Ring #18)

WARRANTY

Great Plains Industries, Inc. 5252 E. 36th Street North, Wichita, KS USA 67220-3205, hereby provides a limited warranty against defects in material and workmanship on all products manufactured by Great Plains Industries, Inc. This product includes a 2 year warranty from date of purchase as evidenced by the original sales receipt. A 30 month warranty from product date of manufacture will apply in cases where the original sales receipt is not available. Reference product labeling for the warranty expiration date based on 30 months from date of manufacture. Manufacturer's sole obligation under the foregoing warranties will be limited to either, at Manufacturer's option, replacing or repairing defective Goods (subject to limitations hereinafter provided) or refunding the purchase price for such Goods theretofore paid by the Buyer, and Buyer's exclusive remedy for breach of any such warranties will be enforcement of such obligations of Manufacturer. The warranty shall extend to the purchaser of this product and to any person to whom such product is transferred during the warranty period.

This warranty shall not apply if:

- A. the product has been altered or modified outside the warrantor's duly appointed representative;
- B. the product has been subjected to neglect, misuse, abuse or damage or has been installed or operated other than in accordance with the manufacturer's operating instructions.

To make a claim against this warranty, contact the GPI Customer Service Department at
316-686-7361 or 800-835-0113. Or by mail at:

Great Plains Industries, Inc.
5252 E. 36th St. North, Wichita, KS, USA 67220-3205

GPI will step you through a product troubleshooting process to determine appropriate corrective actions.

GREAT PLAINS INDUSTRIES, INC., EXCLUDES LIABILITY UNDER THIS WARRANTY FOR DIRECT, INDIRECT, INCIDENTAL AND CONSEQUENTIAL DAMAGES INCURRED IN THE USE OR LOSS OF USE OF THE PRODUCT WARRANTED HEREUNDER.

The company herewith expressly disclaims any warranty of merchantability or fitness for any particular purpose other than for which it was designed.

This warranty gives you specific rights and you may also have other rights which vary from U.S. state to U.S. state.

Note: In compliance with MAGNUSON MOSS CONSUMER WARRANTY ACT – Part 702 (governs the resale availability of the warranty terms).



Wellington Head Office: 90 Sydney St, PO Box 38 720
Petone, Wellington, Tel: 64 4 568 4933, Fax: 64 4 568 4789
Email: sales@liquip.co.nz Website: www.liquip.co.nz